

Xcient

CARGO

DUMP

MIXER

TRACTOR

HYUNDAI XGENT

Annotations

- 1) Chassis cab weight and curb weight shown are to 3.5% variation to allow for production tolerance.
- 2) Chassis cab weight and curb weight include weight of oil, fuel, coolant and spare tire carrier & bracket, spare tire but exclude standard tool set.
- 3) The vehicle specifications may differ per country.
- 4) For further information please contact the commercial vehicle export teams of HMC.
- 5) In order that product improvement may be introduced at any time, specifications are subject to change without prior notice.

310 Cargo Short Wheelbase

HYUNDAI XCINT

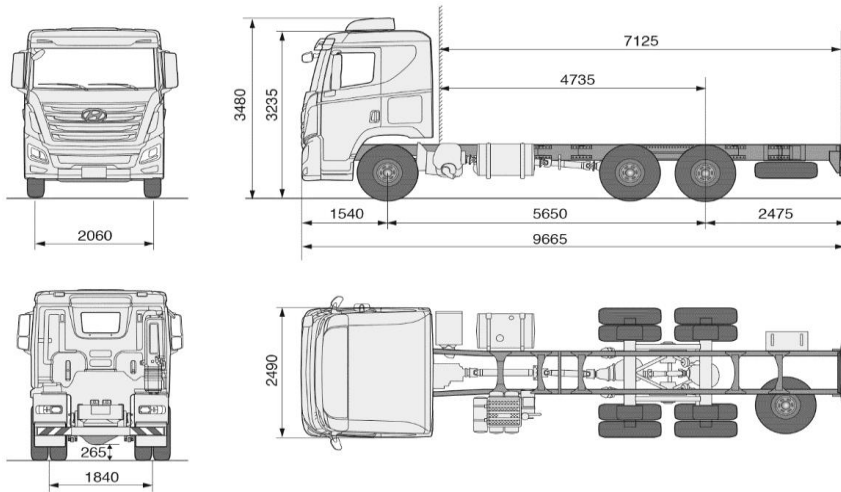

Model		Q340.310 / H380.310 / H400.310			
Vehicle Type		Cargo			
Cab Type		Sleeper Cab			
Drive System		LHD / RHD, 6 x 4			
Wheel Base		Short			
Application Engines		D6AC	D6HB38	D6HA38	D6HA40A
Dimensions (mm)					
Wheel Base		5,650 (4,300 + 1,350)			
Overall (Chassis Cab)	Length	9,665			
	Width	2,490			
	Height	3,235			
Wheel Tread	Front	2,060			
	Rear	1,840			
Overhang (Chassis Cab)	Front	1,540			
	Rear (Frame)	2,390			
C.A (Cab to rear Axle)		4,735			
C.E (Cab to End of frame)		7,125			
Min. Ground Clearance		265			
Min. Turning Radius	m	8.1			
Weight (kg)					
Chassis Cab Weight		8,420	8,595	8,685	8,655
	Front	4,355	4,555	4,625	4,605
	Rear	4,065	4,040	4,060	4,050
** Max Gross Vehicle Weight		30,700			
	Front	7,100			
	Rear	23,600			

** Max. GVW includes the front & rear axle loads based on the permissible tire load.

310 Cargo Medium Wheelbase

HYUNDAI XCIENT

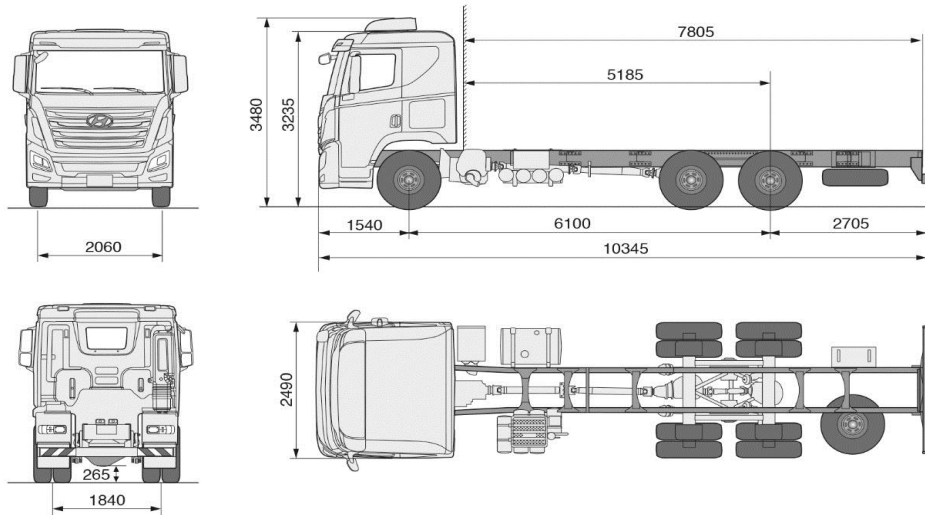

Model	Q340.310 / H380.310 / H400.310				
Vehicle Type	Cargo				
Cab Type	Sleeper Cab				
Drive System	LHD / RHD, 6 x 4				
Wheel Base	Medium				
Application Engines	D6AC	D6HB38	D6HA38	D6HA40A	
Dimensions (mm)					
Wheel Base	6,100 (4,750 + 1,350)				
Overall (Chassis Cab)	Length	10,345			
	Width	2,490			
	Height	3,235			
Wheel Tread	Front	2,060			
	Rear	1,840			
Overhang (Chassis Cab)	Front	1,540			
	Rear	2,620			
C.A (Cab to rear Axle)	5,185				
C.E (Cab to End of frame)	7,805				
Min. Ground Clearance	265				
Min. Turning Radius	m	8.1			
Weight (kg)					
Chassis Cab Weight		8,455	8,625	8,715	8,685
	Front	4,455	4,580	4,650	4,630
	Rear	4,000	4,045	4,065	4,055
** Max Gross Vehicle Weight		30,700			
	Front	7,100			
	Rear	23,600			

** Max. GVW includes the front & rear axle loads based on the permissible tire load.

310 Cargo Long Wheelbase

HYUNDAI XCIENT

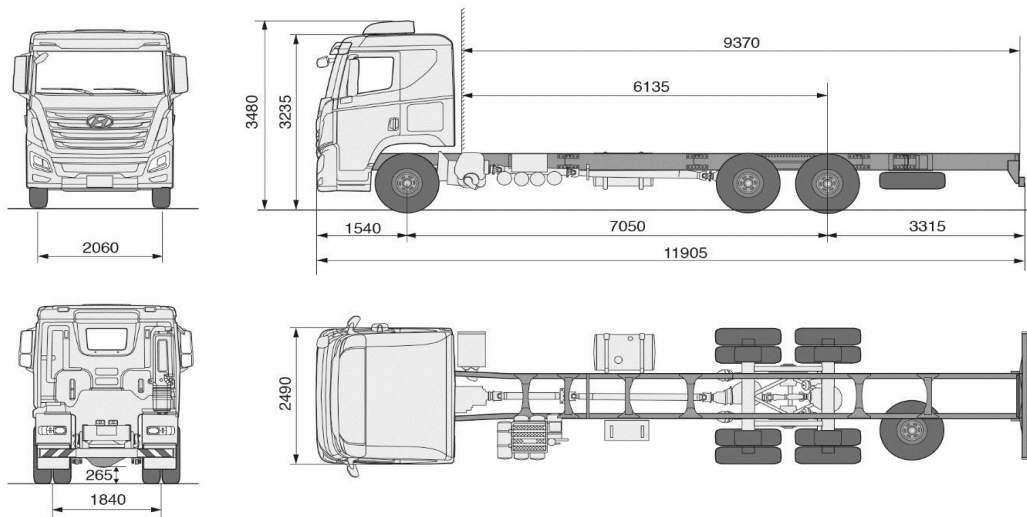

Model	Q340.310 / H380.310 / H400.310			
Vehicle Type	Cargo			
Cab Type	Sleeper Cab			
Drive System	LHD / RHD, 6 x 4			
Wheel Base	Long			
Application Engines	D6AC	D6HB38	D6HA38	D6HA40A

Dimensions (mm)

Wheel Base	7,050 (5,700 + 1,350)	
Overall (Chassis Cab)	Length	11,905
	Width	2,490
	Height	3,235
Wheel Tread	Front	2,060
	Rear	1,840
Overhang (Chassis Cab)	Front	1,540
	Rear	3,230
C.A (Cab to rear Axle)	6,135	
C.E (Cab to End of frame)	9,370	
Min. Ground Clearance	265	
Min. Turning Radius	m	10.4

Weight (kg)

Chassis Cab Weight		8,615	8,800	8,890	8,860
	Front	4,725	4,925	4,995	4,975
	Rear	3,890	3,875	3,895	3,885
** Max Gross Vehicle Weight		30,700			
	Front	7,100			
	Rear	23,600			

** Max. GVW includes the front & rear axle loads based on the permissible tire load.

Chassis Specifications

Engine

Engine	D6AC	D6HB38	D6HA38	D6HA40A	
Type	Turbo Charger Intercooler 4 stroke-cycle, water-cooled, direct-injection diesel engine 6 in-line				
number of Cylinder	6 in-line				
Piston Displacement (cc)	11,149		9,960		
Bore x Stmke (mm)	130 x 140		122 x 142		
Compression Ratio	16.5 : 1		17.0 : 1		
Max. Power** (ps/rpm)	Euro I	340 / 2,200	-	-	
	Euro III	-	380 / 2,000	-	
	Euro IV	-	-	380 / 1,900	
	Euro V	-	-	-	400 / 1,800
	Euro I	140 / 1,400	-	-	-
Max. Torque ** (kg.m/rpm)	Euro III	-	160 / 1,200	-	
	Euro IV	-	-	160 / 1,200	
	Euro V	-	-	-	178 / 1,100
	General	Pressure type with thermostat, Forced circulation by centrifugal water pump			
Cooling System	Radiator	Corrugated fin type with pressure cap and condenser tank			
	Battery	12V x 2, 150 AH at 20 Hr rates			
Electrical System	Alternator	24V-60A	24V-80A		
	Starter	24V-5.5kW	24V-6.0kW		
	Injection pump	In-line type	EUI system		
Fuel System	Governor	All Speed type	Electronic Control		
	Fuel filter		Spin-on type		
Oil System	Lubrication		Forced lubrication by gear pump		
	Oil filter		Full flow and bypass type with paper element		
	Oil cooler		Water cooled, plate fin type		
Valve System	Oil grade		API service classification CD or above		
			Single Overhead Valve, Two valves per cylinder		

** Max. Power and Torque of engine may vary according to each country.

Clutch

Type	Hydraulic control with Air pressure assistance, Diaphragm spring, Single dry plate, Pre-Damper
Facing Material	Non-Asbestos
Facing Size (mm) Outside dia x Inside dia	ø430 x ø242

HYUNDAI XCIENT_310 Cargo

Transmission

Model		Q340.310 / H380.310 / H400.310			
Application Engines		D6AC	D6HB38	D6HA38	D6HA40A
	M12S6	•			
T/M Application	M12S 2X5	o			
• : STD	H160S6		•	•	
o : OPT	H160S 2X5		o	o	
	F50J0309				•
Model type		M12S / H160S6	M12S 2X5 / H160S 2X5	F50 10309	
Type		6 forward and 1 reverse speed, 2nd to 6th synchromesh, 1st & reverse constant-mesh gears	10 forward and 2 reverse speed, 2nd to 10th synchromesh, 1st & reverse constant-mesh gears	9 forward and 1 reverse speed, 2nd to 9th synchromesh, 1st & reverse constant-mesh gears	
Gear Ratio		1st (High / Low) 4.178 2nd (High / Low) 2.587 3rd (High / Low) 1.621 4th (High / Low) 1.000 5th (High / Low) 0.702 6th (High / Low) 7.081 Reverse	9.153 / 7.145 4.783 / 3.733 2.765 / 2.158 1.666 / 1.301 1.000 / 0.780 - 8.105 / 6.327	10.58 / 7.38 5.22 / 3.71 2.73 / 1.99 1.41 / 1.00 0.74 - 10.59	
Gear Oil		API service classification GL5 and SAE service classification 80W/90 (85W/140 : Tropical zones only)			
T.G.S. (Transmission Gear Shift)		Floor shift, Mechanical remote control			

Rear Axle

Application Engines		D6AC	D6HB38	D6HA38	D6HA40A
Type			Full floating type		
Capacity		kg	11,800 x 2		
Final Reduction Gear		Type	Single Reduction, Hypoid gear		
		G/Ratio	6.166 / 5.571	5.571 / 4.875	4.875

Front Axle

Type		Reverse Elliot type " 1 " beam
Capacity		kg 8,000

Tire & Wheel

Type		Single Front, Dual Rear
Tire		Front / Rear 12R 22.5 - 16PR
Wheel		Front/ Rear 8.25T x 22.5-165

Steering

Type		2-Spoke, Ball-nut type, Tilt & Telescopic steering column
Tilting Angle		9 °
Turning Angle		Inner 49 °
		Outer 39 °

Service Brake

		Q340.310 / H380.310 / H400.310			
Engine		D6AC	D6HB38	D6HA38	D6HA40A
Actuation			Full Air, Dual circuit fixed S cam with spring loaded chambers		
Size (mm)	Front		Drum dia. x Lining width x Lining thickness : $\phi 410 \times 156 \times 19$		
	Rear		Drum dia. x Lining width x Lining thickness : $\phi 410 \times 220 \times 19$		
Total lining area			9,635cm ²		

Parking Brake

Actuation	Spring loaded type chamber on the front wheel and the 1st rear wheel (or 1st/2nd rear wheel)		
Size (mm)	Drum diameter x Lining width x Lining thickness Front : $\phi 410 \times 156 \times 19$ / Rear : $\phi 410 \times 220 \times 19$		
Total lining area	6,077cm ² or 9635cm ²		

Exhaust Brake

Type	Air operated, butterfly valve type
------	------------------------------------

Suspension

Type	Front	Semi-elliptic , parabolic leaf springs with shackle link (Taper leaf spring)
	Rear	Semi-elliptic, laminated leaf springs with shackle link (Multi leaf spring)
Shock absorber	Hydraulic double acting telescopic type on the front axle	

Exhaust system

General	Conventional (horizontal) type muffler
Tail pipe	Droptail type, blowing to chassis rearward

Fuel tank

Capacity	400 liter
Material	Steel

Frame

Type	"H" type frame with channel sectional side rail & cross members
Main section side rail dimension (mm)	Depth x Flange x Thickness : 300 x 90 x 8t

380 Cargo Short Wheelbase

HYUNDAI XCINT

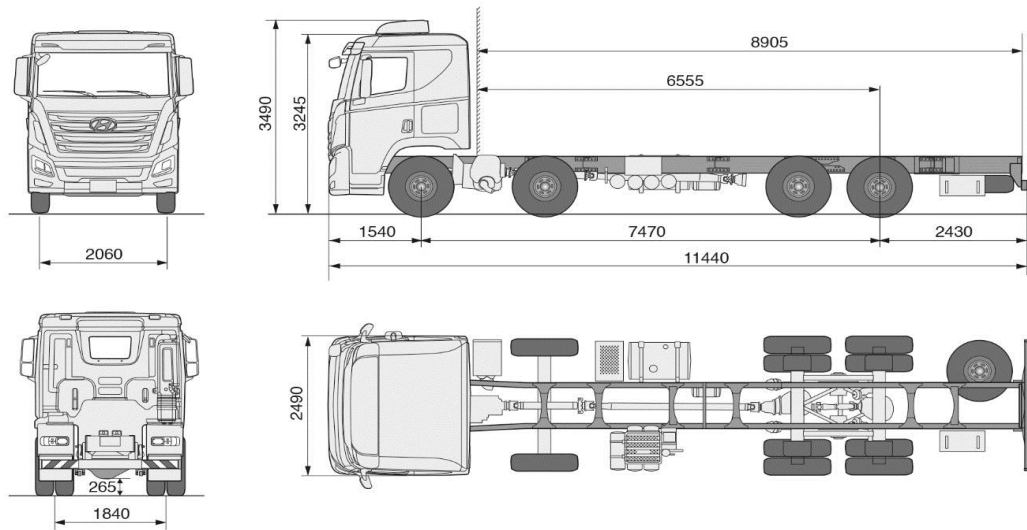

Model	Q340.380 / H380.380 / P410.380		
Vehicle Type	Cargo		
Cab Type	Sleeper Cab		
Drive System	LHD, 8 x 4		
Wheel Base	Short		
Application Engines	D6AC		D6HB38
Dimensions (mm)			
Wheel Base		7,470 (1, 990+4, 130+1, 350)	
Overall (Chassis Cab)	Length	11,440	
	Width	2,490	
	Height	3,245	
Wheel Tread	Front	2,060	
	Rear	1,840	
Overhang (Chassis Cab)	Front	1,540	
	Rear (Frame)	2,350	
C.A (Cab to rear Axle)		6,555	
C.E (Cab to End of frame)		8,905	
Min. Ground Clearance		265	
Min. Turning Radius	m	10.4	
Weight (kg)			
Chassis Cab Weight		10,250	10,350
	Front	7,305	7,405
	Rear	2,945	2,945
** Max Gross Vehicle Weight		38,200	
	Front	13,000	
	Rear	25,200	

** Max. GVW includes the front & rear axle loads based on the permissible tire load.

380 Cargo Extra Long Wheelbase

HYUNDAI XCINT

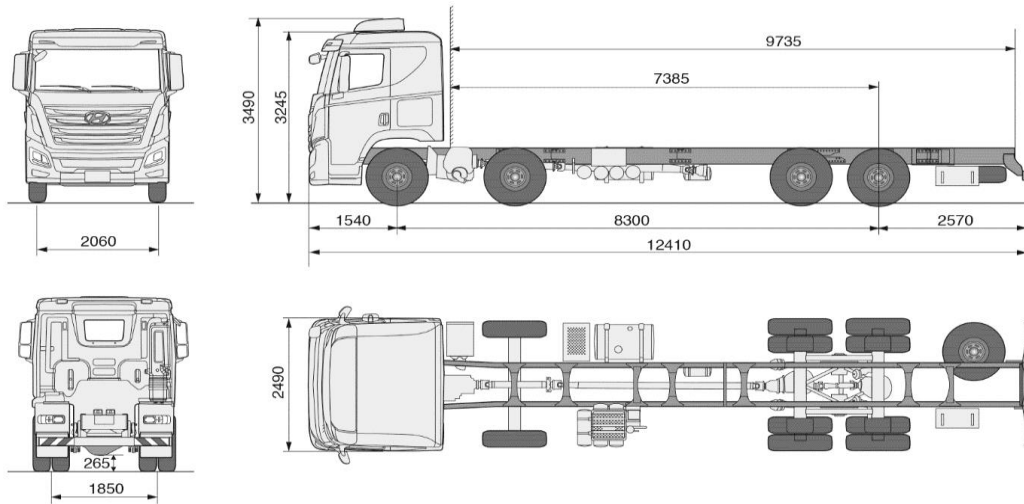

Model	Q340.380 / H380.380 / P410.380			
Vehicle Type	Cargo			
Cab Type	Sleeper Cab			
Drive System	LHD, 8 x 4			
Wheel Base	Extra Long			
Application Engines	D6AC	D6HB38	D6CB41	D6CC41

Dimensions (mm)

Wheel Base	8,300 (1,990 + 4,960 + 1,350)	
Overall (Chassis Cab)	Length	12,410
	Width	2,490
Wheel Tread	Height	3,245
	Front	2,060
Overhang (Chassis Cab)	Rear	1,850
	Front	1,540
C.A (Cab to rear Axle)	Rear (Frame)	2,350
		7,385
C.E (Cab to End of frame)		9,735
Min. Ground Clearance		265
Min. Turning Radius	m	11.6

Weight (kg)

Chassis Cab Weight		10,330	10,430	10,580
	Front	7,320	7,420	7,575
	Rear	3,010	3,010	3,005
** Max Gross Vehicle Weight			38,200	
	Front		13,000	
	Rear		25,200	

** Max. GVW includes the front & rear axle loads based on the permissible tire load.

Chassis Specifications
Engine

Model		Q340.380	H380.380	P410.380	
Engine		D6AC	D6HB38	D6CB41	D6CC41
Type		Turbo Charger Intercooler 4 stroke-cycle, water-cooled, direct-injection diesel engine			
Number of Cylinder		6 in-line			
Piston Displacement (cc)		11,149	9,960		12,344
Bore x Stroke (mm)		130 x 140	122 x 142		130 x 155
Compression Ratio		16.5 : 1		17 :1	
Max. Power** (ps/rpm)	Euro I	340 / 2,200	-	-	-
	Euro III	-	380 / 2,000	410 / 1,900	-
	Euro IV	-	-	-	410 / 1,900
Max. Torque ** (kg.m/rpm)	Euro I	140 / 1,400	-	-	-
	Euro III	-	160 / 1,200	188 / 1,200	-
	Euro IV	-	-	-	188 / 1,200
Cooling System	General	Pressure type with thermostat, Forced circulation by centrifugal water pump			
	Radiator	Corrugated fin type with pressure cap and condenser tank			
	Battery	12V x 2, 150 AH at 20 Hr rates			
Electrical System	Alternator	24V-60A		24V-80A	
	Starter	24V-5.5kW		24V-6.0kW	
Fuel System	Injection pump	In-line type		EUI system	
	Governor	All Speed type		Electronic Control	
	Fuel filter			Spin-on type	
Oil System	Lubrication			Forced lubrication by gear pump	
	Oil filter			Full flow and bypass type with paper element	
	Oil cooler			Water cooled, plate fin type	
Valve System				API service classification CD or above	
				Single Overhead Valve, Two valves per cylinder	

** Max. Power and Torque of engine may vary according to each country.

Clutch

Type	Hydraulic control with Air pressure assistance, Diaphragm spring, Single dry plate, Pre-Damper
Facing Material	Non-Asbestos
Facing Size (mm) Outside dia x Inside dia	ø430 x ø242

HYUNDAI XGENT_380 Cargo

Transmission

Model	Q340.380	H380.380	P410.380
Application Engines	D6AC	D6HB38	D6CB41
T/M Application	M12S 2X5		
• : STD	H160S 2X5		
o : OPT	ZF16S1830		
Model type	M12S2x5 / H160S2x5		ZF16S1830
Type	10 forward and 2 reverse speed, 2nd to 10th		16 forward and 2 reverse speed, 2nd to 10th
	1st (High / Low)	9.153 / 7.145	13.80 / 11.54
	2nd (High / Low)	4.783 / 3.733	9.49 / 7.93
	3rd (High / Low)	2.765 / 2.158	6.53 / 5.46
	4th (High / Low)	1.666 / 1.301	4.57 / 3.82
Gear Ratio	5th(High / Low)	1.000 / 0.780	3.02 / 2.53
	6th (High / Low)	-	2.08 / 1.74
	7th (High / Low)	-	1.43 / 1.20
	8th (High / Low)	-	1.00 / 0.84
	Reverse	8.105 / 6.327	12.92 / 10.80
Gear Oil	API service classification GL-5 and SAE service classification 80W/90 (85W/140 : Tropical zones only)		
TG.S. (Transmission Gear Shift)	Floor shift, Mechanical remote control		

Rear Axle

Type	Full floating type		
Capacity	kg	13,000 x 2	
Final Reduction Gear	Type	Single Reduction, Hypoid gear	
	G/Ratio	6.166	5.571
			3.667

Front Axle

Type	Reverse Elliot type " 1 " beam		
Capacity	kg	6,500 x 2	

Tire & Wheel

Type	Single Front, Dual Rear		
Tire	Front / Rear	12R 22.5 - 16PR	
Wheel	Front / Rear	8.25T x 22.5-165	

Steering

Type	2-Spoke, Ball-nut type, Tilt & Telescopic steering column		
Tilting Angle		9 °	
Turning Angle	Inner	49 °	
	Outer	39 °	

Service Brake

		Q340.380	H380.380	P410.380
Engine		D6AC	D6HB38	D6CB41
Actuation			Full Air, Dual circuit fixed S cam with spring loaded chambers	
Size (mm)	Front		Drum dia. x Lining width x Lining thickness : $\phi 410 \times 156 \times 19$	
	Rear		Drum dia. x Lining width x Lining thickness : $\phi 410 \times 220 \times 19$	
Total lining area			12,155cm ²	

Parking Brake

Actuation		Spring loaded type chamber on the front wheel and the 1st/2nd rear wheel	
Size (mm)	Front	Drum diameter x Lining width x Lining thickness : $\phi 410 \times 156 \times 19$	
	Rear	Drum diameter x Lining width x Lining thickness : $\phi 410 \times 220 \times 19$	
Total lining area		9,635cm ²	

Exhaust Brake

Type	Air operated, butterfly valve type		
------	------------------------------------	--	--

Suspension

Type	Front	Semi-elliptic , parabolic leaf springs with shackle link (Taper leaf spring)
	Rear	Semi-elliptic, laminated leaf springs with shackle link (Multi leaf spring)
Shock absorber	Hydraulic double acting telescopic type on the front axle	

Exhaust system

General	Conventional (horizontal) type muffler
Tail pipe	Droptail type, blowing to chassis rearward

Fuel tank

Capacity	380 liter	350 liter
Material	Aluminum	Steel

Frame

Type	"H" type frame with channel sectional side rail & cross members
Main section side rail dimension (mm)	Depth x Flange x Thickness : 300 x 90 x 8t